



NCT
MATERIAL HANDLING

TL151

Electric Pallet Truck 1.5T **LI-ION** TECHNOLOGY

- New plug-in lithium battery pallet truck;
- Ultimate small size;
- Frame metal forming with high-duty structure.

CE

Electric Pallet Truck 1.5T

TL151

Distinguishing mark	1.1	Manufacturer			NCT
	1.2	Model designation			TL151
	1.3	Drive			Electric
	1.4	Operator type			Seated
	1.5	Load capacity	Q	kg	1500
	1.6	Load center distance	c	mm	600
	1.8	Load distance, centre of drive axle to fork	x	mm	883/946
	1.9	Wheelbase	y	mm	1105/1168
	Service weight	2.1	Service weight		kg
2.2		Axle loading, laden front/rear		kg	574/1096
2.3		Axle loading, unladen front/rear		kg	130/40
Tyres/chassis	3.1	Tyre type			Polyurethane
	3.2.1	Tyre size, front		mm	Φ210x70
	3.3.1	Tyre size, rear		mm	2x Φ78x60(Φ78x88)
	3.4	Additional wheels (castor wheels)		mm	Φ74x48
	3.5	Wheels, number front/rear (x=drive wheels)		mm	1x 2/4 (1x 2/2)
	3.6.1	Tread width, front	b10	mm	438
	3.7.1	Tread width, rear	b11	mm	390
Dimensions	4.4	Lift height	h3	mm	115
	4.9	Height of tiller handle in drive position min./max.	h14	mm	700/1170
	4.15	Lowered height	h13	mm	80
	4.19	Overall length	l1	mm	1525
	4.20	Length to face of forks	l2	mm	375
	4.21	Overall width	b1/b2	mm	600
	4.22	Fork dimensions	s/e/l	mm	50/150/1150
	4.25	Distance between fork-arms	b5	mm	540/685
	4.32	Ground clearance, center of wheelbase	m2	mm	30
	4.34.1	Aisle width for pallets 1000×1200 crossways	Ast	mm	2091
	4.34.2	Aisle width for pallets 800×1200 crossways	Ast	mm	2148
	4.35	Turning radius	Wa	mm	1330
Performance data	5.1	Travel speed, laden/unladen		km/h	4/4.5
	5.2	Lifting speed, laden/unladen		m/s	0.02/0.022
	5.3	Lowering speed, laden/unladen		m/s	0.037/0.021
	5.8	Max. gradeability, laden/unladen		%	5/16
	5.10	Service brake			Electromagnetic
Electric-engine	6.1	Drive motor rating S2 60 min		kW	0.65
	6.2	Lift motor rating at S3 15%		kW	0.8
	6.4	Battery voltage/nominal capacity		V/Ah	24/40
	6.5	Battery weight		kg	13x1
Addition data	8.1	Type of drive control			DC
	10.5	Steering design			Mechanical
	10.7	Sound pressure level at the driver's ear		dB(A)	74

If there are improvements of technical parameters or configurations, no further notice will be given.
The diagram shown may contain non-standard configurations.

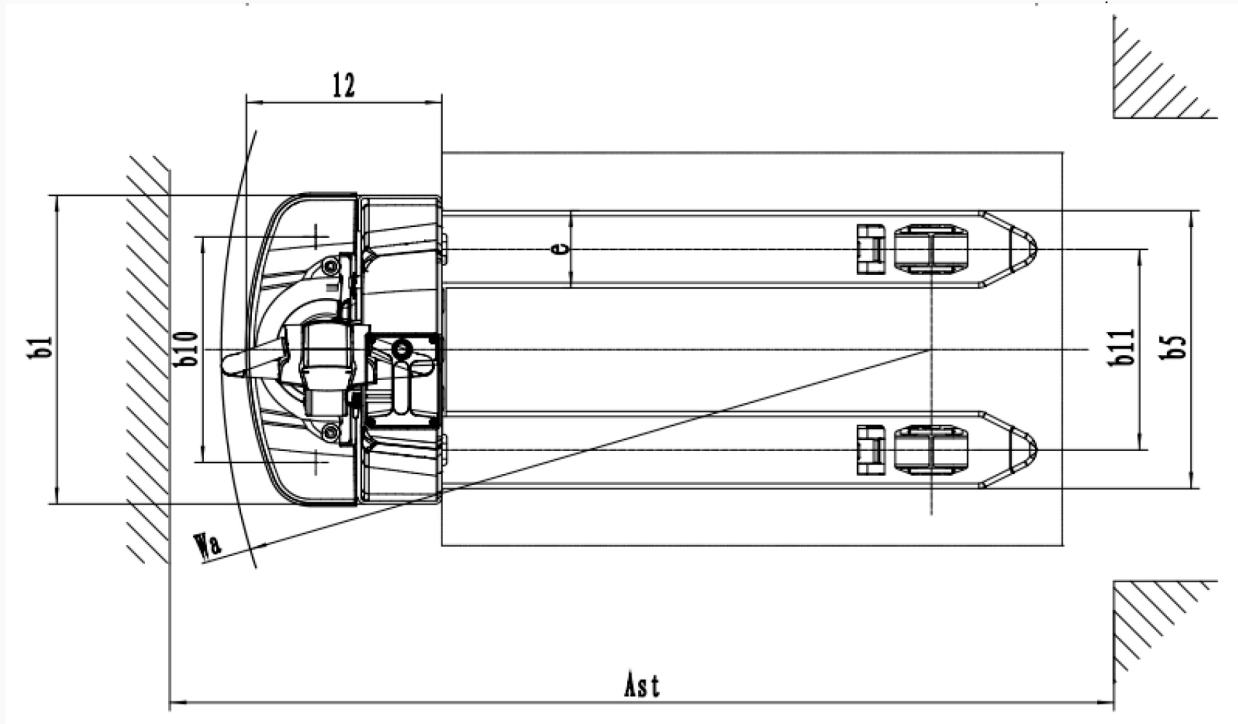
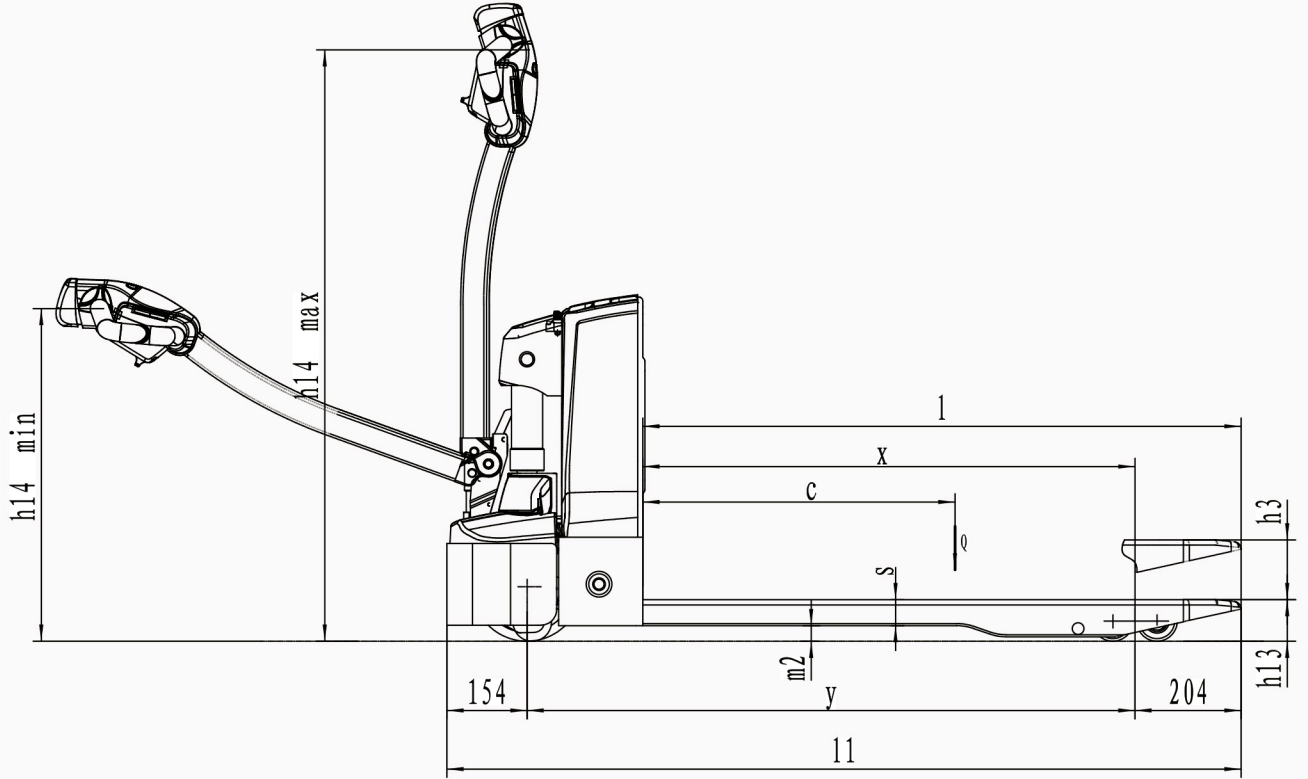

Option

Optional items	TL151
Fork length	○700/800/915/1000/1070/1100/1150/1300
Fork width	○685
Single load wheel	○
Driving wheel	○PU wheel with Pattern
Balance wheel	●
Battery capacity40AH	●
Lithium external charger 24V20A	●
Vertical handler working	○
In and out of the tray guide wheel	○
Special backrest	○1220mm (48in) /1520mm (60in)
Note : Fork length < 1400, capacity1.5T; Fork length≥1400, capacity1.0T	
Note: ● standard ○ option — NA	